

***IMPULSE***      ***SEALER***  
***DIRECT HEAT***

**OPERATION INSTRUCTIONS**

# CONTENTS

1.USAGE AND CHARACTER

2.MAIN DATA AND SPECIFICATIONS

3.ADJUSTMENT AND USAGE

3.1.ADJUSTMENT AND USAGE OF THE IMPULSE SEALER

3.2.ADJUSTMENT AND USAGE OF THE DIRECT HEAT SEALER

4.MAINTENANCE

4.1.MAINTENANCE FOR IMPULSE SEALER

4.2.MAINTENANCE FOR DIRECT HEAT SEALER

5.PACKING LIST

6.TROUBLES AND TROUBLE - SHOOTING

6.1.TROUBLE AND TROUBLE - SHOOTING FOR IMPULSE SEALER

6.2.TROUBLE AND TROUBLE - SHOOTING FOR DIRECT HEAT  
SEALER

7.ELECTRICAL PRINCIPLE DIAGRAM

8.NAME & NO. OF THE SPARE PARTS

## ● OPERATION INSTRUCTIONS ●

### 1.USAGE AND CHARATER

There are two kinds of pedal sealers: impulse sealer and direct heatsealer, Impulse sealer is suitable for sealing polyvinyl chloride, polyethylene bags. Direct heat sealer is suitable for sealing cellophane, aluminium foil, Copper foil, tin foil and polystyrene compound bags and heat prints the production date and expiration date in the seal. The temperature is electronically controlled and is easy to be adjusted. The temperature is stably controlled. The machines are used in the area of food, medicine, daily cosmetics, local specialities, aquatic products, seeds, chemical products, garments etc. They are the best sealers for factories, stores and other areas.

### 2. MAIN DATA AND SPECIFRICATIONS

TYPE	IMPULSE SEALER				DIRECT	HEAT	SEALER
MODEL	KS-F350	KS-F450	KS-F600	KS-F800	KS-DD200	KS-DD300	KS-DD400
LENGTH(MM)	350	450	600	805	200	300	400
WIDTH(MM)	2 5	2 5	2 5	2 5	14	14	14
VOLTAGE	SINGLE PHSE 220V OR 110V/50 60Hz						
SEALING TIME	0 2.5	0 2.5	0 2.5	0 2.5	/	/	/
IMPULSE	1250	1200	1500	1800	150×2	175×2	210×2
POWER(W)							
RANGE OR THE TEMP(°C)	/	/	/	/	0 300°C	0 300°C	0 300°C
DIMENSIONS(MM)	450×510×880	550×520×880	700×570×880	850×650×900			
Wt.(kg)	25	26	28	32	18	21	23

### 3.ADJUSTMENT AND USAGE

#### 3.1 ADJUSTMENT AND USAGE OF IMPULSE SEALER

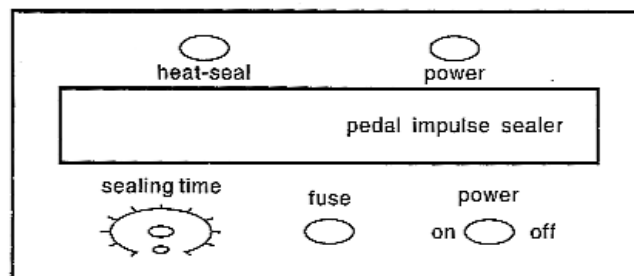

FIG.1. DIAGRAM OF THE CONTROL PANEL FOR IMPULSE SEALER

Connect to 100V/220V power source according to the indication mentioned in the

## ● OPERATION INSTRUCTIONS ●

---

machine, Switch on the power, the red light is on, Adjust the sealing time according to the materials and the thickness of the bags to be sealed. The sealing time should be adjusted to around grade 1 before sealing. Put the opening of the bag into between the heat sealers, step down the pedal and the yellow lamp lights. Take out the sealed bag 1-2sec. After the yellow lamp is off.

If the seal is not tight enough, lengthen the sealing time. Try the bag for several times till it is well sealed with clear figure and no wrinkles. Seal bags at this sealing time and temperature. The cooling time should not be too short, otherwise wrinkles will be caused in the seal. The longer the sealing time, the longer the cooling time.

### 3.2 adjustment and usage of direct heat sealer.

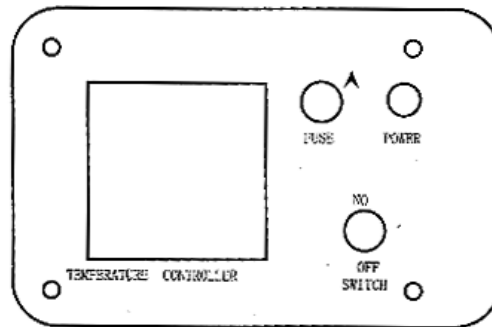

FIG.2 DIAGRAM OF THE CONTROL PANEL FOR DIRECT HEAT SEALER

3.2.1 Loosen the screws for date characters, array the characters according to the requirement and tighten the screws again.

3.2.2 Connect to 110V/220V power source according to the indications mentioned in the machine, Switch on and the red lamp lights. Adjust the temperature according to the material and the thickness of the bags to be sealed. The preset temperature is not reached when the green lamp is still on, When the red lamp is on, the required temperature is reached. It is the right time for working. Put the opening of the bag into between the heaters. Step down the pedal for about 0.2-1.5 sec. And release the pedal. The sealing operation is finished at this time.

3.2.3 If the seal is not tight enough or the date is not well heat printed. It may be because the temperature is too low or the time with the pedal being stepped down is too short. The solution is to raise the sealing temperature and (or) to lengthen the time with the pedal being stepped down.

## ● OPERATION INSTRUCTIONS ●

---

3.2.4 If the bag is melted or the place where the date is printed is broken, for im-pulse sealer, the reason is too long sealing time and for direct heat sealer, the reason is too high temperature or too long time with the pedal being stepped down. The solution is to shorten the sealing time for impulse sealer and for direct heat sealer, to lower the sealing temperature and (or) to shorten the time with the pedal being stepped down.

3.2.5 Switch off the power and unplug the machine when finish working.

### 4. MAINTENANCE

#### 4.1 Maintenance for impulse sealer.

Never try to seal without bags. Don't set the sealing time to the high grade without and trials. Otherwise, the teflon cloth will be burned. If some plastics unfortunately adheres to the teflon cloth because of carelessness, never try to scrape it with something hard. Just slightly reduce the sealing time and seal the bag again. Release the pedal a little after the yellow lamp is off. It is very important to get out the bag from one side to the other. The remains of the plastics will be cleared from the teflon cloth with the bag.

##### 4.1.1 Replacement of the heater

Loosen the screws of the plate pressing the teflon cloth, roll back the cloth to let out the heater, loosen the bakelite boxes at both sides of the heater and get out the screws on the copper block, Now the heater can be removed. Replace it with a good new one. The heater should always be in tension with the function of the spring. The copper block should be tilled if it is oxydised, to ensure it has a good connection with the heater, Pay attention when fixing the heater so that the teflon cloth below is flat (no wrinkles are allowed). And the heater must have an excellent isolation. Otherwise the heater will be damaged because of the short-circuit.

##### 4.1.2 Replacement of teflon cloth

Remove the screws and the plates above the teflon cloth, loosen the shaft of the teflon cloth roll, pull out the cloth and cut the burned part. Reassemble the plates and screws, tighten the roll shaft. No wrinkles are allowed in the teflon cloth, otherwise the seal quality will be affected.

##### 4.1.3 Replacement of the micro-switch

There is one micro-switch at the side of the machine head. It must be replaced when it is damaged. The adjustment of the pressing pole for micro-switch: Put 1mm thick carton between the upper and lower and lower pressing arms, check if the micro-switch is

## ● OPERATION INSTRUCTIONS ●

---

pressed and if there is a "click" from the switch, if it is not pressed, adjust down the pressing pole or tighten the nut c3 till the switch is pressed 1 2mm down when it works.

4.1.4 Always keep the sealing surface clean. Otherwise, the remains in the sealing surface will shorten the life of the heater and the life of the teflon cloth. When working, never try to clean the sealing surface with wet cloth.

4.1.5 After long time usage, the rubber in the upper pressing arm must be checked if it is still flat and straight. Otherwise, the seal quality will be affected.

4.1.6 Often add lubricating oil into the moving parts.

4.1.7 All parts in the machine should not be disassembled casually.

### 4.2 Maintenance for direct heat sealer

4.2.1 Always keep the surface of the date character clean. Avoid any remains on the sealing surface to guarantee the quality of the seal, date printing and the life of the machine.

4.2.2 Never try to clean the sealing surface with wet cloth when the power is still connected. Never touch the heating block with hand in case of being burned.

4.2.3 The same model of the theater must be used when replacing.

4.2.4 Attention not to connect high voltage source to "+", "-" inputs or to thermocoupling in case not to damage the temperature controller.

4.2.5 After long time usage, check if the rubber on the upper pressing arm is flat and straight. Otherwise, the quality of the seal may be affected. Check if the wire connection of the heater and the heater is in good position.

4.6 Often add lubricating oil into the moving parts.

4.7 Don't disassemble any parts in the machine casually.

## 5. PACKING LIST

Parts of the machine	1 set
Wrench 6"	1
Cross screw driver 3"	1
Straight screw driver 3"	1
Fusee 2-15a	2-4
Teflon cloth	1 (for impulse sealer only)
Heat sealers	2 (for impulse sealer only)
Heater	1 (for direct heat sealer)
Operation manual	1

## ● OPERATION INSTRUCTIONS ●

### 6. TROUBLES & TROUBLE-SHOOTING

#### 6.1 For impulse sealer

TROUBLES	CAUSER & SOLUTIONS
The seal is no good	To lengthen the sealing time if seal is not tight enough. To shorten the sealing time if the seal is melted. Or The melted seal is caused by not being pressed tightly.
The seal is wrinkled	1. Overheating. Shorten the sealing time as possible on the condition that the good seal of the bag is guaranteed. 2. Insufficient time for cooling. Lengthen the cooling time.
The temperature rises when working for some time	it is normal that the temperature of machine will rise because the machine is started at the room temperature, it absorbs some heat during the operation. Shorten the sealing time slightly to balance the heat.
The power lamp doesn't light and the sealer does not work	Check if the power switch is on, if the fuse is all right.
The power lamp lights but the sealing lamp is off and the sealer doesn't work.	Step down the pedal to check if the micro-switch works well. See 4.13 for adjustment.
The sealer is always electrified when the power is switched on	Switch the power off at once. Check if the micro-switch is all right. See 4.13 for adjustment.

#### 5.2. For direct heat sealer

TROUBLES	CAUSE & SOLUTIONS
The seal is no good.	To lengthen the time with the pedal being stepped down or to raise the sealing temperature. If the seal is not tight enough. Or vice versa, if the seal is melted.
There is wrinkles in the seal	1. Overheating. Shorten the sealing time as possible on the condition that the seal of the bag is guaranteed. 2. The time with the pedal being stepped down is too long. Shorten this time.
Both power lamp and the lamp of the temp. Controller don't light.	Check if the connection of the heater is in good condition, if the heater is all right, if the thermocoupling is no problem and if the connection of the coupling is ok.
The temperature is out of control.	1. The thermo-coupling is damaged or not well connected. 2. There is a problem in the temperature controller.

# ● OPERATION INSTRUCTIONS ●

## 7.ELECTRICAL PRINCIPLE DIAGRAM

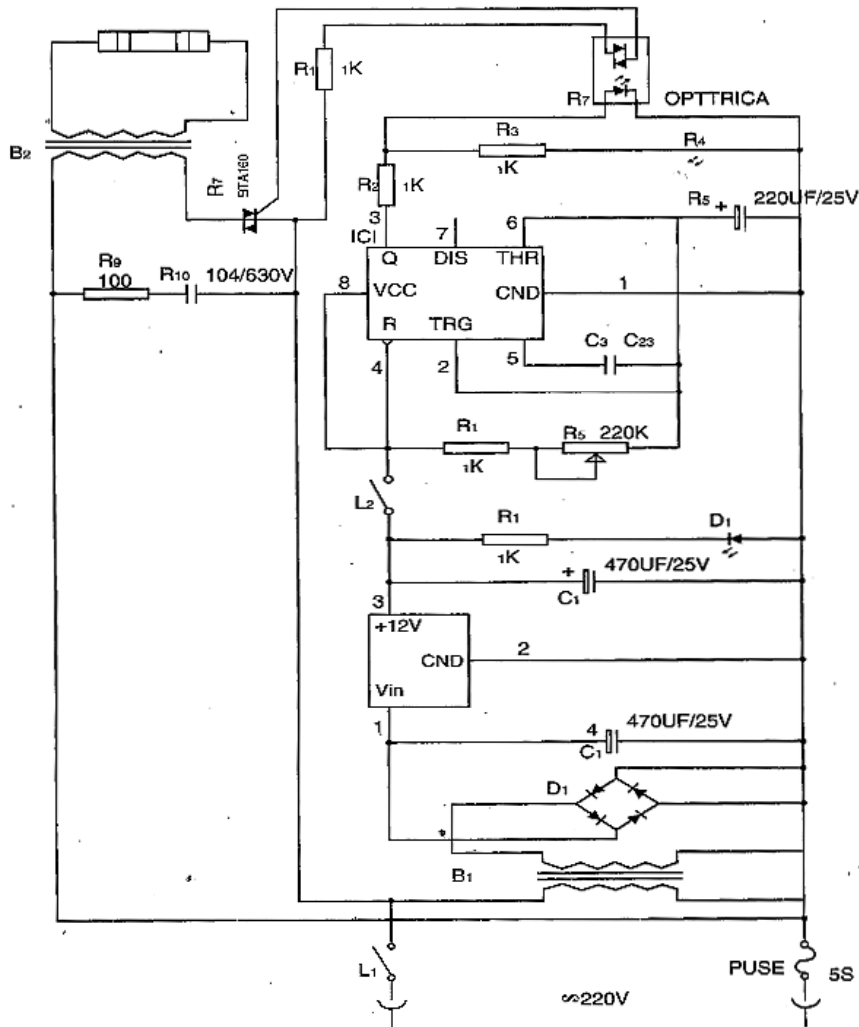

FIGURE 3. ELECTRICAL PRINCIPLE DIAGRAM FOR IMPULSE SEALER

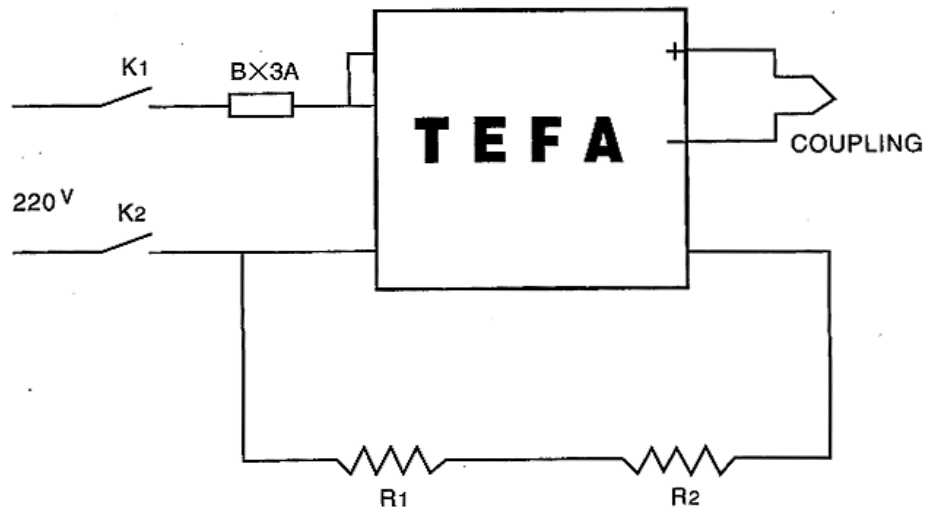
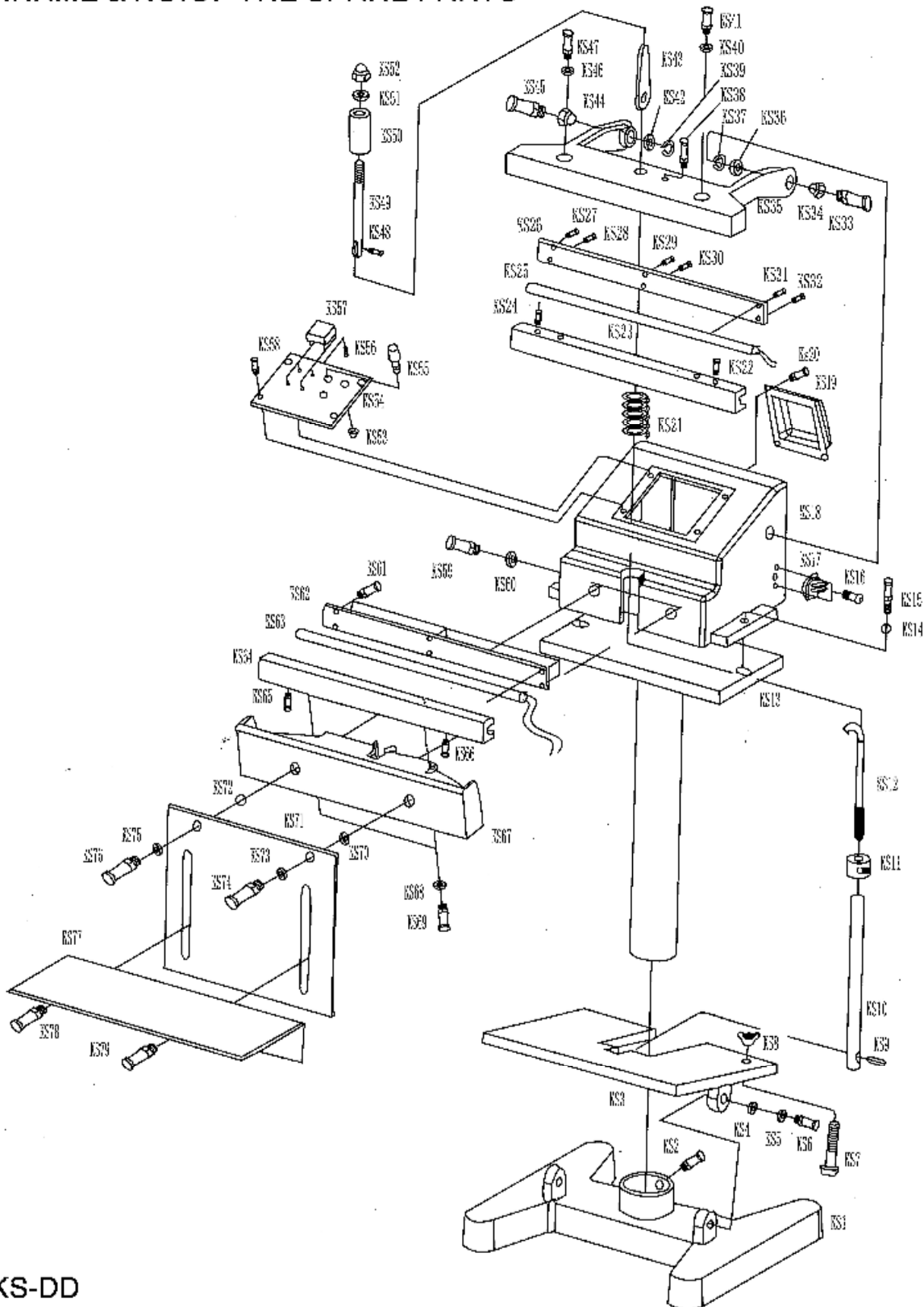

FIGURE 4. ELECTRICAL PRINCIPLE DIAGRAM FOR DIRECT HEAT SEALER



# ● OPERATION INSTRUCTIONS ●

## 8.NAME & NO.OF THE SPARE PARTS



KS-DD

FIG.5. SHAFTS DIAGRAM FOR KS-DD DIRECT HEAT SEALER

## ● OPERATION INSTRUCTIONS ●

NO	NAME	QUANTITY	NO	NAME	QUANTITY
KS1	machine base	1	KS44	Tetrafluorohydrazine convention	1
KS2	bolts	1	KS45	outter hex bolts group	1
KS3	pedal board	1	KS46	flat washer	1
KS4	flat washer	1	KS47	outter hex bolts	1
KS5	nuts	2	KS48	flexible pin	1
KS6	bolts	1	KS49	polling pole	1
KS7	adjusting bolts	1	KS50	rubber cushion	1
KS8	butterfly nuts	1	KS51	screw conention	1
KS9	flexible pin	1	KS52	cap nut	1
KS10	pedal pulling pole	1	KS53	power indicator lamp	1
KS11	connecting nuts	1	KS54	operation panel	1
KS12	hooker polling pole	1	KS55	power switch	1
KS13	column base	1	KS56	Cross recessed pan head screw	4
KS14	nuts	2	KS57	temperature controller	1
KS15	screws and flat washer	2	KS58	Cross recessed pan head screw	4
KS16	wire guider	1	KS59	out hex bolt group	1
KS17	Cross recessed pan head screw	2	KS60	flat pad	1
KS18	shell	1	KS61	Cross recessed pan head screw	6
KS19	out cover	1	KS62	heater pressor	1
KS20	inner hex screws	4	KS63	heater	1
KS21	spring	1	KS64	lower hating block	2
KS22	outer hex bolts	1	KS65	bolts groups	1
KS23	upper heating block	1	KS66	bolts groups	1
KS24	outer hex bolts	1	KS67	lower fasten base	1
KS25	coupling	1	KS68	flat pad	2
KS26	coupling board	1	KS69	outter hex bolts	2
KS27	Cross recessed pan head screw	1	KS70	flat pad	1
KS28	Cross recessed pan head screw	1	KS71	flat pad	2
KS29	Cross recessed pan head screw	1	KS72	fix board of worktable	1
KS30	Cross recessed pan head screw	1	KS73	flat pad	1
KS31	Cross recessed pan head screw	1	KS74	outter hex bolts groups	1
KS32	Cross recessed pan head screw	1	KS75	flat pad	1
KS33	bolts group	1	KS76	out hex bolt rroup	1
KS34	tetrafluorohydrazine convention	1	KS77	work table	1
KS35	upper sealing pressor	1	KS78	outter hex bolt group	1
KS36	tetrafluorohydrazine pad	1	KS79	outter hex bolt group	1
KS37	flexible pad	1			
KS38	inner hex bolts	1			
KS39	flexible pad	1			
KS40	flat washer	1			
KS41	inner hex screws	1			
KS42	flexible pad	1			
KS43	small connecting board	1			

# ● OPERATION INSTRUCTIONS ●

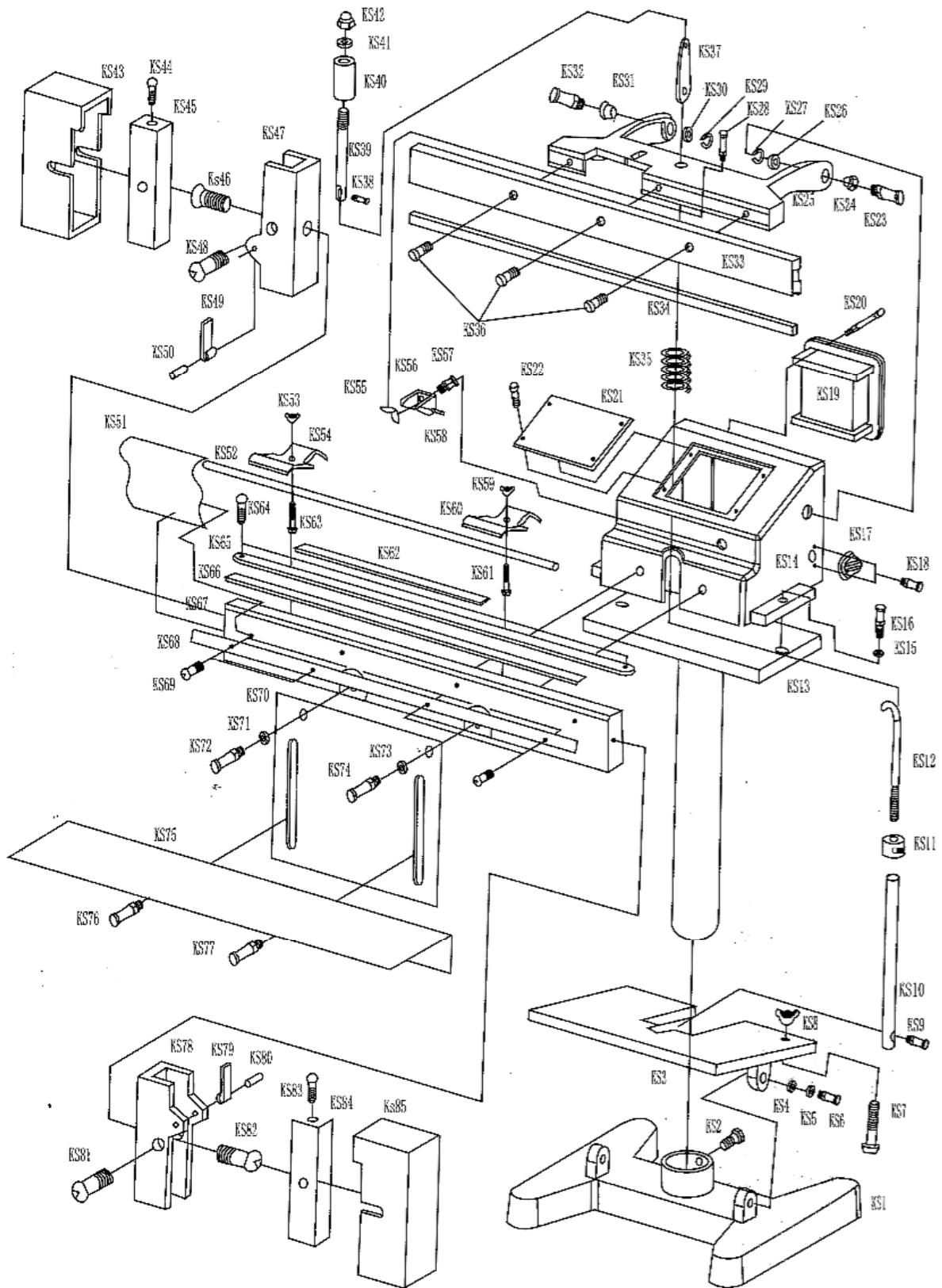

FIG.7. SHAFTS DIAGRAM FOR KS-F IMPULSET SEALER

## ● OPERATION INSTRUCTIONS ●

NO	NAME	QUANTITY	NO	NAME	QUANTITY
KS1	Machine base	1	KS44	Cross recessed pan head screw	1
KS2	bolt	1	KS45	copper pole	1
KS3	pedal board	1	KS46	Countersunk flat head screws	1
KS4	flat washer	1	KS47	ceramic base	1
KS5	nut	2	KS48	Cross recessed pan head screw	1
KS6	bolt	2	KS49	metal pressor	1
KS7	adjusting bolt	1	KS50	pin	1
KS8	butterfly nut	1	KS51	tefelon	1
KS9	bolt groups	1	KS52	axes for the tefelon	1
KS10	pedal board tie	1	KS53	butterfly nuts	1
KS11	connecting nut	1	KS54	hold-down plate	1
KS12	hoker tie	1	KS55	tuching board	1
KS13	upright column base	1	KS56	approximaty switch shelf	1
KS14	machine cover	1	KS57	approximaty switch	1
KS15	nut	2	KS58	pin	1
KS16	screw and flat gasket	2	KS59	butterfly nuts	1
KS17	wire guider	1	KS60	pressor	1
KS18	Cross recessed pan head screw	2	KS61	bolt	1
KS19	transformers and back cover	1	KS62	insulated pad	1
KS20	bolt	4	KS63	bolt	1
KS21	operation pannel	4	KS64	Countersunk flat head screws	2
KS22	Countersunk scres	4	KS65	heater	1
KS23	bolt groups	1	KS66	insulated pad	1
KS24	tetrafluorohydrazine convention	1	KS67	lower sealing fasten base	1
KS25	upper sealing shelf	1	KS68	tefelon pressor	1
KS26	tetrafluorohydrazine convention	1	KS69	Cross recessed pan head screw	1
KS27	flexible mat	1	KS70	fasten board of working table	1
KS28	inner hex screw and nut	1	KS71	flat cushion	2
KS29	flexible mat	1	KS72	bolts froups	1
KS30	flat washer	1	KS73	flat mat	1
KS31	tetrafluorohydrazine convention	1	KS74	bolts groups	1
KS32	bolt gruoups	1	KS75	flat	1
KS33	pper sealing silicon fasten block	1	KS76	bolts groups	1
KS34	silicon rubbers	1	KS77	bolts groups	1
KS35	spring	1	KS78	ceramic base	1
KS36	inner hex screw	1	KS79	metal pressor	1
KS37	small connecting board	1	KS80	pin	1
KS38	flexible pin	1	KS81	Cross recessed pan head screw	1
KS39	tie	1	KS82	Countersunk flat head screws	1
KS40	rubber cushion	1	KS83	pin	1
KS41	washer	1	KS84	corn column	1
KS42	cap nuts	1	KS85	plastic cover	1
KS43	plastice cover	1			